

# Kenyan Top Bar Hive

## East Bay Basic

courtesy of [www.sparkybeegirl.com](http://www.sparkybeegirl.com)

Dimensions in inches based on 3/4" plywood for a box with 26 bars cut all pieces. assemble four sides of box upside down with wood screws. attach bottom of box with overhang on entrance side. attach 1" stop bar to front end.

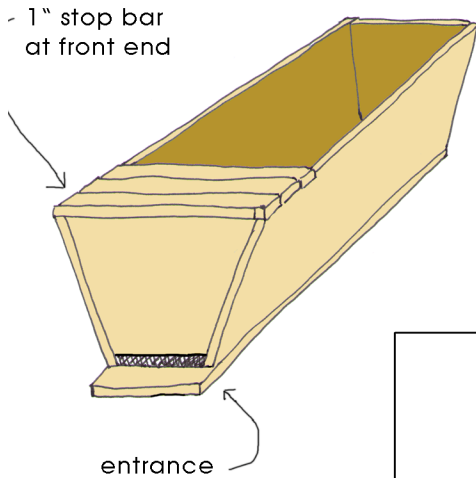

**LID (optional)**  
**18 x 43**

if you don't ever need to transport your hive, a sheet of plywood will suffice to keep rain off. Otherwise add a 1x2 lip around the edge that will sit down around the top bars, Add a tie down strap and the bars will be fixed into place and ready for transport.

**SIDE**  
**12 x 39-1/4**

**BOTTOM**  
**10 x 40-1/4**

**SIDE**  
**12 x 39-1/4**

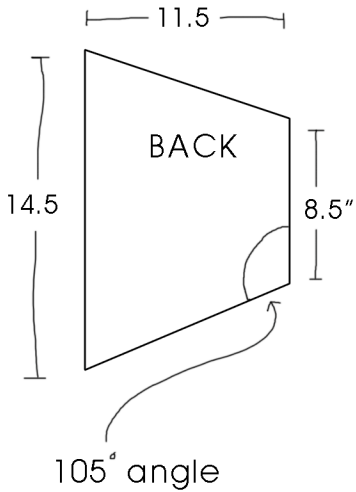
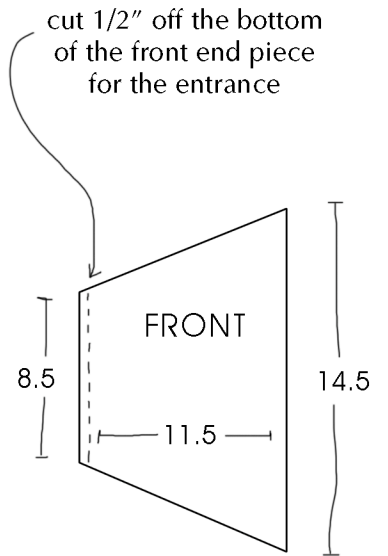

for extra clean assembly cut 15 off bottom edge of side pieces with table saw

Cut top bars from solid wood. They should be 16" long, at least 3/4" thick and between 1-3/8" and 1-1/2" wide. Use a 1/8 inch wide saw blade to cut a groove 1/8" wide and 3/8" deep down the middle on one side. Cut guide bars from 1/8" plywood 1" x 13.5". Affix guidebar into groove with a few drops of wood glue.

